

Agricultural Residues as Promising Biofuels for Biomass Power Generation in Thailand

M. Barz^{1,2,3,*} and M.K. Delivand^{1,2}

¹The Joint Graduate School of Energy and Environment (JGSEE), King Mongkut's University of Technology Thonburi, Thailand

²Centre of Energy, Technology and Environment, Ministry of Education, Thailand

³Hochschule für Technik und Wirtschaft (HTW) – University of Applied Sciences Berlin, Germany

*Corresponding Author: barz@htw-berlin.de

Abstract: Since Thailand is an agricultural-based economy, there are various resources of agricultural residues which can be used for electricity Generation. To what extent those residues penetrate future energy markets depends on various aspects, e.g. the availability of the resources, the logistic frame conditions for the fuel supply, the state of the art of conversion technologies and opportunities for technological developments, the costs of electricity generation and last but not least environmental, social and institutional factors. This paper indicates which agricultural sources could be used as promising energy sources and analyzes the potential contribution in terms of electricity generation. An overview about the viable conversion routes and technologies is presented and discussed.

Keywords: biomass, agricultural residues, energy potential, logistics, conversion routes, combustion, gasification, biomass IGCC, biogas, rice straw, rice husk.

1. Introduction

The use of renewable resources for energy production is a strategic focus of governmental institutions to restructure the national energy economies and many efforts are undertaken to increase the share of renewable energies within the national energy supply structures in Thailand [1]. Biomass, as the most important source of renewable energy in use today is widely accepted for its potential to satisfy environmental compatibility. Nevertheless, the issues of bioenergy and biofuel development are discussed controversy caused by various impacts such as possible negative environmental impacts, losses on biodiversity or the competition of food crops versus energy plantations. To prevent negative effects from bioenergy developments in the future, international institutions such as FAO, EC and others provided proposals on sustainability requirements/sustainability criteria's for the production and use of biomass sources for energy purposes [2-3]. Such sustainability criteria encompass not only ecological but also technical, economical and social aspects, which must always be considered collectively and in their interactions [4]. Biomass best practice guidelines, which can be derived from sustainability criteria are focused on a successful development and implementation of bioenergy projects, securing reliable and cost effective supply of biomass fuels for a project and to ensure that proposals and planning's for bioenergy projects can proceed in an appropriate manner (with regard to minimize possible negative environmental and social impacts that a bioenergy project might generate). Best practice guidelines are addressed to give recommendations to policy makers, local authorities, project developer, and investors and as well for plant operators and biomass feedstock suppliers. In opposite to projects which are designed to maximize the short-term profit of investors without or with little consideration for the wider issues involved, best practice projects are designed to remain sustainable in the long term, based on full life cycle analysis and to ensure that the bioenergy industry maintains its reputation of being responsible in the future [5]. The use of agricultural residues as energy sources is in compliance with those best practice guidelines and can contribute to ensure a sustainable development of the energy sector, especially since beside the always accepted environmental advantages, there is no competition with food or feed production and no land use change required.

2. Background conditions

The future success of bioenergy developments in Thailand depend on many factors, such as the policy framework conditions, the availability of suitable and high efficient conversion technologies, the long term and cost effective biomass fuels supply security, and the impacts on environmental and social issues.

In Thailand, the national energy policy promotes renewable energy to address the key issues on energy security, the reduction of energy imports and the reduction of greenhouse gas emissions. Among other instruments the Energy Conservation Promotion Fund is the government's tool to implement power purchase and subsidy programs for power producer from Renewable Energy. Promotional Measures are the provision of "Adder" for power generation using Renewable Energies and the provision of soft loans for the implementation of Renewable Energy projects [1]. For power generation from biomass the rate of adder (or feed-in premium) varies on the installed capacity of a project and is fixed for a supporting period of 7 years. Projects with an installed capacity of ≤ 1 MWel receive a feed in premium of 0.5 THB/kWh, projects above 1 MWel only 0.3 THB/kWh. Special adder of 1 THB/kWh is provided if projects are implemented in three of the Southern Provinces.

Since Thailand is a tropical country and the climate is offering an ideal environment for Biomass production, bioenergy is the most important Renewable Energy in use today.

Table 1. Electricity Generation from Renewable Sources in Thailand, Source DEDE [6].

RE Source	Unit	Existing capacity in Sept 2009	Share
Wind	MW	5.13	0.3
Solar	MW	37.6	2.0
Hydro	MW	67	3.6
Biomass	MW	1,729.2	94
- Solid Biomass		(1,644)	
- Biogas		(79.6)	
- MSW		(5.6)	
Total electricity from RE MW		1839	

Within the Alternative Energy Development Plan (AEDP) of the Thai Government until the year 2022 a tripling of Power Generation and a significant increase of liquid biofuel production

for the transportation sector is expected. Thus, the demand for biomass as energy source will inevitably increase over time, putting pressure on fuel supply security and associated topics. If sustainability requirements do not receive the necessary consideration, this pressure might affect pricing for agricultural products and food security supply aspects too. For this reason, the use of agricultural residues as Energy sources offers a promising opportunity to promote the future development of bioenergy utilization. Since using agricultural residues as energy sources will not interfere with food security, such fuels will meet the requirements for a future sustainable based energy supply.

3. Biomass Potential in Thailand

Thailand has abundant biomass sources for energy and many studies have been undertaken to assess the available potentials. Prasertsan and Sajjakulnuki [7] calculated that the total energy potential of biomass from agricultural residues, new plantation, animal waste, biomass conservation, fuel substitution, municipal solid waste (MSW), industrial waste water, black liquor and palm-oil mill effluent in 1997 was at 475.4 PJ, covering 15% of the total primary energy consumption of the country. Following projections of the estimated biomass potentials for 2010 and up to the future vary very much. Most studies focus on estimations of the biomass potential based on productivity assumptions for energy crops and the authors don't give indications which terms of biomass potentials, such as "technical potential", "economical potential" or "sustainable usable potential" have been considered within their studies. Uncertainties exist further in terms of the practiced method of data acquisition and the consideration of competitive uses or regarding general questions as e.g. which agricultural residues or waste streams could become available in the near future. Some reliable data were provided by Bureau of Energy Research, Department of Alternative Energy Development and Efficiency, Thailand [7-9] and the Centre of Energy, Technology and Environment, Ministry of Education, Thailand (studies, carried out by the Joint Graduate School of Energy & Environment at KMUTT) [10-12]. All of these studies indicate that agricultural residues are the most promising biomass sources in Thailand, estimating their quantitative availability on a sustainable basis would represent an energy content between 560 [12] – 620 PJ [8]. The total amount of agricultural residues in Thailand, quantified by Sajjakulnukit et al. is about 61 million ton per year, of which 41 million ton (which is equivalent to about 430 PJ) were unused [7].

4. Agricultural residues as biomass sources for power generation

A classification of agricultural residues can be made into process based residues, such as rice husk, bagasse or empty fruit bunches from palm oil industries and so called field based residues, such as straw. Juninger et al. expect that if only all process-based agricultural residues alone would be used, they could contribute between 25% and 40% of the total primary commercial energy production in various Southeast Asian countries [14].

Until now, the two major biomass resources being used for power generation in Thailand are bagasse (approx. 15–17 Mio t/year), a byproduct of sugar production, and rice husk (approx. 5 Mio t/year), which remains after milling rice [7,13]. Since in Thailand, the bagasse as byproduct of the sugar production is almost completely used for electricity and heat generation at the sugar mills, it is estimated that no additional amounts of this source are available for power generation. But it is an interesting issue, that with regard to studies carried out by JGSEE, the efficiencies of the installed conversion units are very low. A study of Siemers [13] indicates that bagasse represents a theoretical electricity generation potential of 8,400

GWh, but the current power generation is limited to only about 1,000 GWh/year, caused by the quite low overall conversion efficiencies. Siemers showed in his studies, that a doubling of the current electricity generation from bagasse up to 2,000 GWh/year could be reached as a realistic intermediate approach by quite simple efficiency improvements (investments in new boilers and/or new turbines)[13].

Rice husk is the second major biomass source, used for electricity generation in Thailand. Approximately 7 Mio t of rice husk, representing an energy content of about 100 PJ are produced as a by-product after milling every year [15]. Approx. 5,000 GWh electricity could be generated by using all of this husk for power generation (considering an overall power generation efficiency of the existing rice husk power plants of about 20%). Since huge quantities of husk are produced in centralized rice mills and thus, the logistical efforts to bring the husk to power plant sites nearby are manageable; approx. 50-60% of the produced rice husk is already used for power generation in conventional thermal (steam cycle) power plants. Most rice husk fired power plants in Thailand are located in the central and northern regions of Thailand, where rice is the main agricultural product and thus the transportation costs are limited. But many operators of rice husk power plants are facing serious problems. Today, there are too many rice husk power plants in the same area, leading to a high competition to receive sufficient amounts of husk as fuels and finally to a drastic rise in fuel prices. Some operators started the business when the fuel price was only determined by the transportation cost to bring the husk from the rice mills to the power plant sites (sometimes below 100 THB/t), but today rice husk is a high priced good with costs, depending on the location, between 900 THB/t up to 1,600 THB/t in some regions (see figure 1).

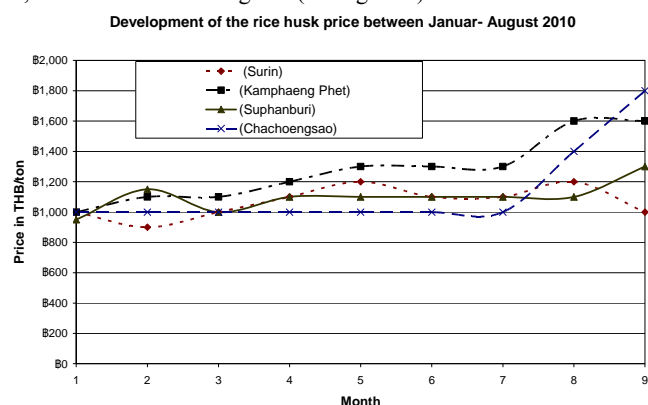

Figure 1. Development of rice husk prices as fuel in 2011 [15].

Caused by the increased prices and the related uncertainties in fuel supply security, the power plant operators are struggling with economic problems to ensure a profitable operation. For this reason, it is not expected that further new large scale rice husk fired power plants (capacity ranges between 10-20 MWe) will be established. Project developer are now looking for alternative opportunities, such as small scale gasification units (power range up to 1 MWe), where the fuel supply security risks are limited and more easily manageable. Further advantage of gasification projects could be a wider flexibility concerning the use of alternative fuels. But the central question is, whether the limited commercial available gasification technologies are suitable to be implemented in Thailand. The main objective of ongoing collaborative development activities between technology provider and science institutions are focused on solving technological problems such as ash- and slag fouling problems in the gasification reactor and the generation of sufficient synthesis gas qualities (caloric value, tar content, particulate matter content etc.).

Beside the so called process based residues, the field based residues (such as rice straw or sugar cane leaves and tops) represent a much larger amount of available Biomass resources in Thailand. The underlying assumption behind the agricultural residue supply curve is that after each harvesting cycle of agricultural crops, a portion of the stalks can be collected and used for energy production. Agricultural residues cannot be completely extracted, because some of them have to remain in the field to maintain soil quality (i.e., for erosion control, carbon content, and long-term productivity). It is assumed that 30 to 40% of the residues could be removed from the soil, depending on the location [19]. In Thailand, the amount of field based residues as energy sources is very low until now. The major reason why these field based resources are widely unused was the unclear logistics and the costs of the resources for larger scale projects [13].

A comprehensive supply chain analysis for the rice straw-fueled power generation in Thailand was provided by Delivand et al. [1,10]. Considering that the logistics of the fuel supply have a large impact on the economy of a biomass power generation facility, especially for low density biomass fuels like straw it was shown that combustion of rice straw in thermal power plants is a promising opportunity (see table 2) in terms of economy.

Table 2. Economic and financial analysis of power generation from rice straw in Thailand (Conventional direct fired steam cycle based biomass power generation concept, based on an investment scenario of 30% equity and 70% loan).

Parameter	Capacity 5 MWe	Capacity 8 MWe	Capacity 10 MWe	Capacity 20 MWe
NPV (MB)	-65	13	120	480
IRR (%)	-	9	12	16
PB (year)	-	6.9	6.2	5.3

Results of this study are easily adoptable to other field based agricultural residues as e.g. sugar cane leaves and tops. Since until now open field burning is the common practice to remove the residues from the field and to prepare the field for the next crop, using this residues for power generation will reduce the emissions of unwanted and harmful compounds such as hydrocarbons or nitrous oxides, which are usually formed in high concentrations during an uncontrolled combustion [1]. A further benefit is the mitigation of GHG emissions by the substitution of fossil fuels for power generation.

5. Conversion technologies for agricultural residues - general process overview

The generation of electricity from biomass encompasses a wide range of different possible conversion processes (see figure 2).

The most important factors that influence the choice of conversion processes are the type of the biomass fuel and the fuel properties, the available quantity of biomass and as well environmental standards; economic conditions; and project specific factors [16]. This paper is considering the two main applicable conversion routes, the thermochemical and bio-chemical/biological processes. The third route, physical-mechanical conversion route (e.g. plant oil extraction and use of the liquid biofuels in internal combustion engines) is not considered since most of the liquid biofuels in Thailand are used as fossil fuel substitutes within the transportation sector.

6. Thermochemical conversion

The thermochemical conversion processes require fuels with high heating values and for this reason lower water contents of the biomass fuels. The most common process is the direct combustion of the fuels to produce thermal energy, which can be used e.g. for steam production and in further steps for electricity generation by using steam turbines, steam engines or other energy converter [17]. Further suitable thermochemical processes are gasification and pyrolysis processes, which will convert the biomass into so called secondary bio-fuels, such as combustible gases or oils as a fuel for gas engines and gas turbines to generate electricity (see figure 2). A promising advanced Biomass Power Generation concept for the future is the combination of gasification technologies with advanced gas turbines to biomass integrated gasification combined cycle (IGCC) concepts which will result in higher efficiencies compared to conventional Biomass Power Technologies. Net conversion to electricity is projected to be approximately 35% for biomass IGCC plants, compared to 20 to 25% for conventional biomass combustion plants [18]. IGCC is a proven concept for coal-based power generation (reaching electrical efficiencies up to 50% in large scale applications), but since up to now only large scale applications seem to be economic feasible, the conventional steam cycle processes will remain the most important technological solutions for the next years.

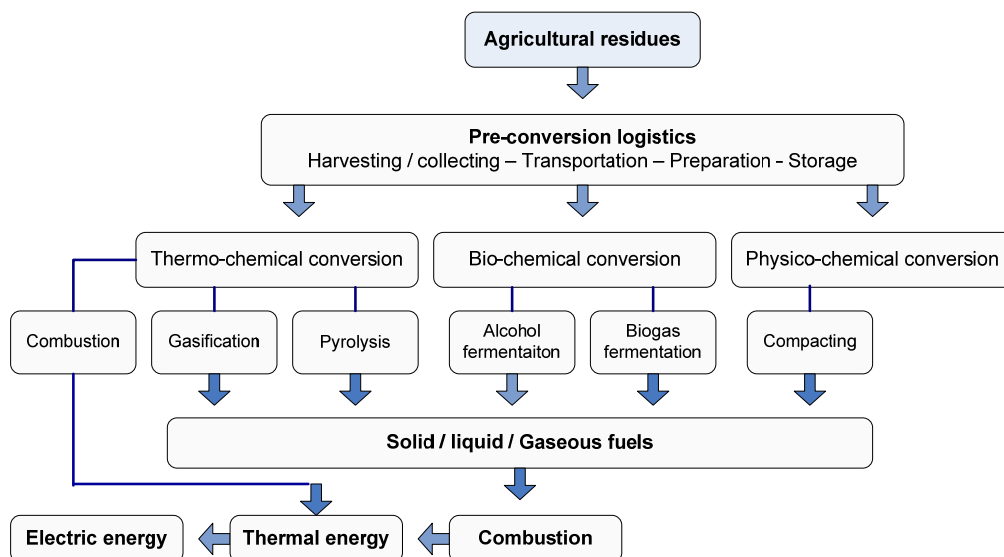

Figure 2. Conversion routes for agricultural residues.

7. Conventional direct fired steam cycle based Biomass Power Generation

The conventional conversion technologies for solid biofuels by combustion have a great importance for the electricity generation. Most of the biomass power generation plants use direct fired systems, whereby the biomass is burned directly and the released thermal energy is used to produce steam leading to the generation of electricity via so called conventional steam cycle processes. The combination of direct biomass combustion technologies, steam generators and power generation facilities like steam turbines, steam engines, steam screw engines and ORC systems is already established at market and the power range between 0,1 – max. 20 MW meets the requirements of the decentralized utilization of biomass. Most of the systems (especially in the lower power range below 20 MW) are grate boilers, whereby the fuel is fed to the grate with the help of mechanical or pneumatic fuel feeders. The fuel is burned on the grate and the hot combustion gases are passing through heat exchanger to generate high pressure and high temperature steam to run a steam turbine (see figure 3). Most of the biomass power plants are operated with relatively low temperature and pressure steam parameters (steam pressures of between 30-65 bar and temperatures between 450-485°C). Such systems can reach typical net electrical efficiencies between 20-25%, depending on plant capacities and steam parameters. Since there is a correlation between plant capacities and technological complexity, only some demonstration plants are operated with increased steam parameters reaching higher electrical efficiencies of approx. 30% (e.g. the 35 MWel biomass power plant at Fynsværket in Denmark works at 112 bar/540°C and reaches 29.9% efficiency) [20].

Fluidized bed combustion systems can be economically used for higher plant capacities and such systems are for this reason a promising opportunity for co-firing systems with coal in large scale applications. The biomass co-firing in coal-fired power plants offers significant advantages: it is highly efficient, approximately between 36% and 44%, depending on the efficiency of the coal-fired unit (39-46%) [20]. Such co-firing with coal is the most-simplest way to use biomass since an existing coal-fired power plant is used and this is more cost-effective than building a new power plant. Typical share of biomass in such co-firing systems is between 10-20 % contributing to the substitution of the coal and related environmental issues such as the mitigation of greenhouse gases.

8. Biomass Integrated Gasification Combined Cycle (IGCC) Power Generation

Integrated gasification combined cycle power plants (IGCC) have been developed and demonstrated for power generation using fossil fuels such as coal as feedstock since many years [21]. Principle of the technological concept is the generation of burnable gases via a gasification process, the use of the synthesis

gas to run a gas turbine for electricity generation in a first power generation step and the further use of the hot flue gas from the gas turbine for steam generation, which will be used for electricity generation in a conventional steam cycle process as a second power generation step (see figure 4).

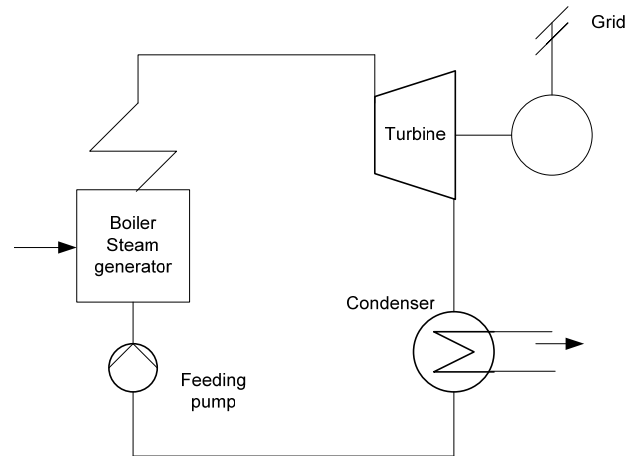

Figure 3. Flow sheet diagram of conventional steam cycle for power generating.

The combination of both power generation processes (gas turbine + steam turbine) will result in an increased electrical efficiency (projected electrical conversion efficiencies for biomass IGCC are above 35%) and reduced greenhouse gas emissions (see figure 5).

Biomass IGCC power generation process is technically viable as demonstrated at the Biomass IGCC project in Värnamo, Sweden. But critical issues are still the high necessary technological efforts as e.g. gas cleaning to ensure a long term reliable operation. The removal of tars, alkalis and PM is a great challenge for biomass IGCC facilities and high temperature methods to remove these compounds must be improved. Current research for biomass-derived syngas cleanup is focused on the catalytic cracking of tars, sintered metal candle filters for particulate removal, and high temperature alkali capture [18].

Further obstacles are, that IGCC facilities are more expensive to build than conventional direct fired power plants and that a limited reliability is currently being considered as the most important process-related problem of IGCC plants [22]. However, the further development of biomass IGCC is a central research focus of several R&D projects and a multitude of research institutions and commercial enterprises started extensive R&D efforts trying to solve the existing problems. Biomass IGCC might be for Thailand a promising opportunity to use agricultural residues as energy sources in the future. Up to now the direct fired steam cycle based biomass power generation concepts seem to be more favorable for the implementation of new projects in Thailand.

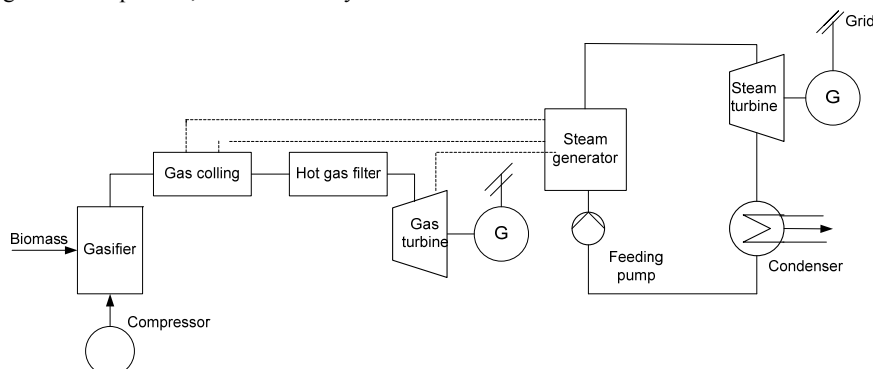

Figure 4. Flow sheet diagram of biomass IGCC power plant.

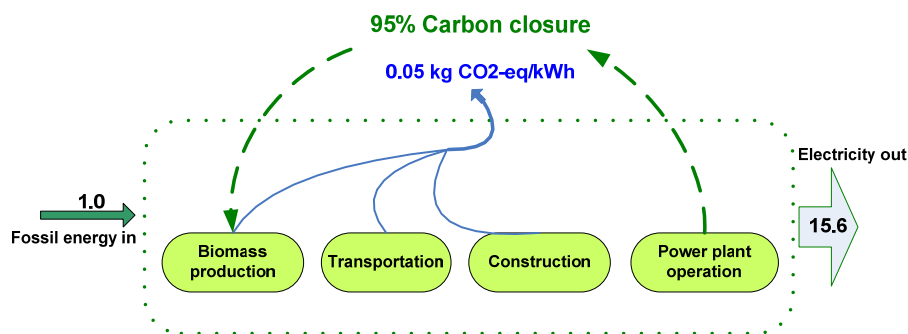

Figure 5. Life cycle GWP balance for advanced biomass IGCC technology (adopted from Ref. [23]).

9. Biomass gasification and power generation in internal combustion engines (IC)

Biomass gasification is a thermo-chemical conversion process, aimed to convert solid biomass into a gaseous fuel, a so called syngas (usually characterized by low caloric values between 4- 6 MJ/m³) which can be used in combustion engines or steam turbines (see biomass IGCC) to generate electricity.

Most of the biomass gasification systems in use today are auto-thermal operated partial oxidation reactors, where just sufficient amount of air (typical excess air ration $\lambda \approx 0.25$) is introduced to the main reaction zone to burn a part of the biomass and to provide the required thermal energy for the endothermic pyrolysis and gasification processes. The reaction products are gaseous components such as CO, H₂, CH₄, CO₂, H₂O (representing the syngas); solid products like char and ash and some condensable products such as tars and condensable vapors. A huge variety of gasification technologies, including fixed bed technologies such as updraft and downdraft gasifier, entrained flow gasifier and fluidized bed gasifier are available.

In most of the small scale applications (< 1 MWth) the biomass is gasified in a fixed bed (e.g. downdraft) gasifier, and the produced gas is then wet-scrubbed to condense tars and reduce syngas temperature. The gas is then used in an internal combustion engine for power generation. This technology might be a promising opportunity for the gasification of rice straw or empty fruit bunches from the palm oil industry and other agricultural residues in Thailand in decentralized small scale applications for power generation. Biomass gasifier technology and internal combustion engines are available at the market. JGSEE carried out a techno-economic assessment study about rice straw gasification project opportunities in Thailand and as a main result it was shown, that projects with capacities higher than 1 MWel could create a positive net present value (NPV), resulting in an IRR of about 8% and a payback period of about 7.5 years. But a commercial implementation of such projects requires that the still existing drawbacks such as system reliability, relatively high operation and maintenance costs (caused e.g. due to the necessary efforts to clean up the syngas and to ensure a long term reliable performance of gas engines) have to be solved.

Fluidized bed gasification systems are more complex and for this reason more cost intensive than fixed bed gasification systems. The application area for fluidized bed gasification is thus more feasible for larger scale power generation projects (>3 MWel). In Thailand, some test plants (prior to commercialized applications) are designed to use rice husk as biomass fuel. Drawbacks recognized until now is the poor syngas quality and the high concentration of unwanted components such as tars and PM which might be caused by insufficient process control measures. But as the high ash content, the low bulk density, poor flow characteristics and low ash melting point makes the other types of reactors like grate

furnaces and downdraft gasifiers either inefficient or unsuitable for rice husk conversion to energy, the fluidized bed reactor system seems to be the promising choice for this kind of fuel in the future [24]. Since rice husk is already widely used in Thailand for power generation in larger scale direct fired steam cycle based biomass power plants, applications for rice husk gasification in the power range of 3 MWel could be a beneficial solution for locations where sufficient fuel amounts are available at rice mills and long distance transportation to existing power plants is unprofitable.

10. Biochemical conversion

As shown in figure 2, the most important biochemical conversion processes are alcoholic fermentation to produce ethanol and anaerobic digestion processes to produce biogas. In Thailand, agro-industrial scaled alcohol fermentation is focused to produce bio-ethanol-blended gasoline which is consumed in the transportation sector. There is no noteworthy use of bio-ethanol in the power generation sector known for Thailand until now. Furthermore, considering the governmental targets to increase the biofuel share in the transportation sector no considerable bio-ethanol use for power generation is expected for the future.

Agricultural residues, especially the wastes from four big agro-industries in Thailand (cassava pulp, pineapple peel, decanter cake and empty fruit bunches) can be used to produce biogas via anaerobic digestion processes. The biogas can be afterwards used in internal combustion engines to generate electricity. Currently, the overall annual biogas production in Thailand is approximately 234 million m³/year with an energy content suitable to produce approx. 2,000 GWh of electricity [25-26]. Although Thailand is an agricultural country with a large volume of potential biogas feed-stocks, only two major sources are currently used for biogas production. These are wastewaters from cassava starch factories and pig farms [26]. Paepatung et al. [26] presented a potential study for biomethane production from agricultural residues in selected agro-industries of Thailand (see table 3).

Table 3. Bio-methane and Energy Potential from residues of four agro-industries in Thailand (adopted from [26]).

Biomass Source	Methane potential (million m ³ per year)	GWh	Ktoe
Cassava pulp	425	3,989	343
EFB	179	1,686	145
Decanter cake	19	186	16
Pineapple peel	21	197	17
Total	644	6,058	521

As shown in table 3, a tripling of the current power generation from biogas would be possible, using only the agricultural residues considered in four of Thailand's agro

industries. It is obvious that the total power generation potential from biogas in Thailand is much higher. Prasertsan and Sajjakulnukit [7] calculated that biogas technologies implemented into the waste water treatment of 10 agro - and food processing industries, such as sugar industries, slaughter houses, breweries etc. could generate additional 2,500 GWh electricity. Further huge potentials can be expected if high moisture containing materials from landscaping such as grasses or troublesome plants and weeds like water hyacinths could be used as substrates in advanced biogas technologies, e.g. dry fermentation systems in the future.

Summary

Thailand has abundant biomass resources for power generation. Caused by governmental targets to increase the share of renewable energies within the national energy mix and since biomass is the most important renewable energy source used in Thailand, the demand for biomass as energy source will inevitably increase over time, putting pressure on fuel supply security and associated topics. To what extent biomass will penetrate future energy markets depends on various aspects, e.g. the availability of the resources, the costs of biomass fuels, the development of conversion technologies, cost of converted biomass energy and social and/or institutional factors [28]. The use of agricultural residues as an energy source is a promising opportunity to reduce this pressure, since the use is, in the most cases, in compliance with sustainability criteria such as the protection of resources, compatibility with environment and climate, social compatibility issues, low risk and error tolerance and is furthermore offering a comprehensive economic efficiency. It is estimated that agricultural residues could provide up to 25% of the total primary energy demand of the country [27] and a considerable share could be used for power generation. Within the different conversion routes, the thermo chemical conversion routes offer promising opportunities for those residues that are predominantly dry such as rice straw and husk and the biological routes such as anaerobic digestion for residues which are predominantly wet such as e.g. empty fruit bunches (EFB) from palm oil industry. Direct combustion technologies (Conventional direct fired steam cycle based Biomass Power Generation) are state of the art and available in Thailand too. There is an increasing interest in gasification technologies for power generation, but a commercial implementation has not yet been received since the still existing drawbacks such as system reliability, relatively high operation and maintenance costs have to be solved first. Cooperation between universities, manufacturers and investors can help to solve such problems and support the implementation in the near future. A further promising opportunity would be the implementation of integrated combined technologies such as Biomass IGCC power plants, but up to now the direct fired steam cycle based biomass power generation concepts seem to be more favorable for Thailand since barriers such as high investment costs and system reliability obstacles have to be solved.

Within the biological conversion technologies the development of power generation from biogas might be termed as a success story. Biogas technologies were introduced to Thailand in the early 50's using Indian floating drum systems for dairy farms. A remarkable further development began with the introduction of more advanced systems within the Thai-German Biogas Programme (TG-BP) from 1988-1995 which was supported by the German Technical Cooperation (Deutsche Gesellschaft fuer Technische Zusammenarbeit GmbH-GTZ) and carried out in cooperation with Chiang Mai University and the Department of Agricultural Extension, Ministry of Agriculture, Thailand. Currently, wastewaters from cassava starch factories

and pig farms are the main sources used for biogas production in Thailand. An enormous increase of the power generation from biogas is possible if residues from other agro processing industries and further high moisture containing biomass sources could be used as substrates.

Acknowledgement

The authors are grateful to the Joint Graduate School of Energy and Environment (JGSEE), King Mongkut's University of Technology Thonburi, Thailand, the Center for Energy Technology and Environment, Ministry of Education, Thailand and to the Energy Policy Planning Office, Ministry of Energy Thailand providing support to the project "Sustainable Use of Bioenergy in Thailand".

References

- [1] Barz M, Delivand MK, Rice Straw – A Promising Bioenergy Source in Thailand and Other Asian Countries, *Proceedings of the International Conference on Innovations for Renewable Energy (IRE 2010)* Hanoi, Vietnam (2010).
- [2] SEC(2010) 65, *Report from the Commission to the Council and the European Parliament on sustainability requirements for the use of solid and gaseous biomass sources in electricity, heating and cooling* (2010) Brussels, yyy COM (2010) XXX final.
- [3] FAO-BEFSCI, *1st FAO-BEFSCI Technical Consultation on "Criteria and Indicators on Sustainable Bioenergy Production that Safeguards Food Security"* (FAO Headquarters, Rome, 2-4 November 2009).
- [4] BMU, *Renewable Energies - Innovations for the future* (2006) Federal Ministry for the Environment, Nature Conservation and Nuclear Safety (BMU), Germany.
- [5] Sims REH, *Bioenergy Project Development & Biomass Supply – Best Practice Guidelines* (2007) OECD/IEA.
- [6] Sinsukprasert P, *Energy Efficiency and Renewable Energy Policies toward Low Carbon Society* (2010) Seminar on Fostering Economic Growth through low carbon initiatives in Thailand, Chulalongkorn University, Bangkok, 25-26 Feb 2010
- [7] Prasertsan S, Sajjakulnukit B, Biomass and biogas energy in Thailand: Potential, opportunity and barriers, *Renewable Energy* 31 (2006) 599–610.
- [8] Sajjakulnukit B, Yingyuad R, Maneekhao V, Pongnarintasut V, Bhattacharyab SC, Salamb AP, Assessment of sustainable energy potential of non-plantation biomass resources in Thailand, *Biomass and Bioenergy* 29 (2005) 214–224.
- [9] Sajjakulnukit B, Verapong P, Sustainable biomass production for energy in Thailand, *Biomass and Bioenergy* 25 (2003) 557–570.
- [10] Delivand MK, Barz M, Gheewala SH, Logistics cost analysis of rice straw for biomass power generation in Thailand, *Energy* 36/3 (2011) 1435-1441.
- [11] Garivait S, Chaiyo U, Patumsawad S, Deakhuntod J, *Physical and Chemical Properties of Thai Biomass Fuels from Agricultural Residues* (2006) The 2nd Joint International Conference on Sustainable Energy and Environment (SEE 2006) 1-23 November 2006, Bangkok, Thailand
- [12] Garivait S, Chanthunyagarn S, Gheewala SH, *Bioenergy Atlas of agricultural residues in Thailand* (2004) The Joint International Conference on Sustainable Energy and Environment (SEE) 1-3 December 2004, Hua Hin, Thailand
- [13] Siemers W, Greenhouse gas balance for electricity production from biomass resources in Thailand, *Journal of Sustainable Energy & Environment* 1 (2010) 65-70.

- [14] Junninger M, Faaij A, van den Broek R, Koopmans A, Hulscher W, Fuel supply strategies for large-scale bio-energy projects in developing countries, Electricity generation from agricultural and forest residues in Northeastern Thailand, *Biomass and Bioenergy* 21/4 (2001) 259-275.
- [15] Sarasuk K, *Design parameters for a lab-scale two-stage rice husk gasification system* (2011) Master Thesis for the degree of Master of Energy Technology and Management, JGSEE, Bangkok.
- [16] McKendry P, Energy production from biomass (part 2): conversion technologies, *Bioresource Technology* 83 (2002) 47–54.
- [17] Barz M, Biomass Technology for Electricity Generation in Community, *International Journal of Renewable Energy* 3/1 (2008).
- [18] Black & Veatch, *Advanced biopower technology assessment, assessment report prepared for the Massachusetts Division of Energy Resources & Massachusetts Department of Conservation & Recreation* (2008).
- [19] Haq Z, Biomass for electricity generation, Energy Information Administration
<http://www.eia.doe.gov/oiaf/analysispaper/biomass/>
- [20] IEA ETSAP, *Biomass for Heat and Power, Technology Brief E05* (2010) www.etsap.org
- [21] Stahl K, Neergaard M IGCC Power plant for biomass utilization, Varnamo, Sweden, *Biomass and Bioenergy* 15/3 (1998) 205-211.
- [22] Liu H, Ni W, Li Z, Ma L, Strategic thinking on IGCC development in China, *Energy Policy* 36 (2008) 1–11.
- [23] Spath PL, Mann MK, *Biomass power and conventional fossil systems with and without CO2 Sequestration – Comparing the energy balance, greenhouse gas emissions and economics* (2004) NREL-Technical Report, NREL/TP-510-32575.
- [24] Natarajan E, Nordins A, Rao AN, Overview of combustion and gasification of rice husk in fluidized bed reactors, *Biomass and Bioenergy* 14/5-6 (1998) 33-546.
- [25] Paepatung N, Kullavanijaya P, Loapitinan O, Songkasiri W, Nopparatana A, Chaiprasert P, *Assessment of Biomass Potential for Biogas Production in Thailand* (2006) Final report submitted to The Joint Graduate School of Energy and Environment, Bangkok, Thailand (in Thai).
- [26] Paepatung N, Nopparatana A, Songkasiri W, Bio-Methane Potential of Biological Solid Materials and Agricultural Wastes, *As. J. Energy Env.* 10/01 (2009) 19-27.
- [27] FAO, *Biomass energy in ASEAN member countries, produced by the FAO Regional Wood Energy Development Programme (RWEDP) in Asia in cooperation with the ASEAN-EC Energy Management Training Centre and the EC-ASEAN COGEN Programme* (Bangkok, 1997) <http://www.fao.org/sd/egdirect/egan0008.htm>
- [28] Hoogwijk M, Faaij A, B Eickhout B, de Vries B, Turkenburg W, Potential of biomass energy out to 2100, for four IPCC SRES land-use scenarios, *Biomass and Bioenergy* 29/4 (2005) 225-257.